

An MOH Licensed Company



*First Time in Health care "Professionals
with a Excellent Energy Saving Concept"*

COMPANY PROFILE

15%

**Energy Saving
Guaranteed**

UNICORN MEDICALS LLC

OFFICE/WH No: 15, ABDULLA ALI BIN HAIDER BUILDING,
UMM AL RAMOOL
DUBAI – UAE, Po. Box. 231673

Tel: 00971 4 2500178, Mob: 00971 50 4759990, Email: info@unicornmed.com; s.john@unicornmed.com





INTRODUCTION

Unicorn Medicals has been established as a Health Care Establishment in Dubai, United Arab Emirates. Our traditional business model is based on the Health Care requirement in the Middle East, India and North-East African Countries.

Founded in 2007, with the aim of bringing quality health care solution in Energy Saving, MEP, Interior fit out, Medical Engineering Sector, Laboratory and Dental industry as a service provider – Specialized Piped Gas Systems, Bed Head Units, Pendants, Modular Operating Rooms, Clean Room Systems, Pneumatic Tube Systems, Nurse Call Systems, Centralized Clock System and other hospital infrastructure services. Further we started our direct operation Middle East, India and East, North-East African Countries with unrivalled experience and capabilities.

Unicorn Medicals has developed a strong reputation as a procurement specialist, distributor and supply chain manager in the wider Industrial and healthcare industry as well as Project management and It has expanded its offer, supplying a variety of Industrial and healthcare products.

Unicorn Medicals developed and implemented a Quality Management System in order to document the company's best business practices, better satisfy the requirements and expectations of its customers and improve the overall management of the company. The Quality Management System of Unicorn meets the requirements of the international standard **ISO 9001: 2015, ISO 45001 : 2018, ISO 14001 : 2015 & ISO 13485 : 2016.**

VISION, MISSION, VALUES & GOALS

Our Vision

To provide quality services that exceeds the expectations of our esteemed customers and become a complete Health care infrastructure Engineering solution provider.

Our Mission

To build long term relationships with our customers and clients and provide exceptional customer services by pursuing business through innovation and advanced technology and Delightful Operation World Wide.

Core values

We believe in treating our customers with respect and faith We grow through creativity, invention and innovation. We integrate honesty, integrity and business ethics into all aspects of our business functioning.

Goals

Regional expansion in the field of Health Care, develop a strong base of key customers. Increase the assets and investments of the company to support the development of services. To build good reputation in the field of Health Care Industry and Project management and become a key player in the Health Care industry.

HOW WE BEGAN?



ESTABLISHMENT Company was founded under name Unicorn Medicals in UAE.



Skilled Tech Electro-Mech - Doha, Qatar For Electromechanical works



Unicom Medicals WLL – Doha, Qatar For Medical Engineering works



Unicom Technical Services – Dubai, UAE For Electro Mechanicals



Unicom Africa Ltd, Uganda For East-North Africa Operations



Unicom Global Trading & Bussiness SPC - Oman
Unicom Technical Services - Riyadh. Saudi Arabia
Unicom Enterprises - Chennai, India



Unicom Enterprises- Kolkata, India For India Operations



Unicom Medicals For **Abu Dhabi** Region



ORG - CHART

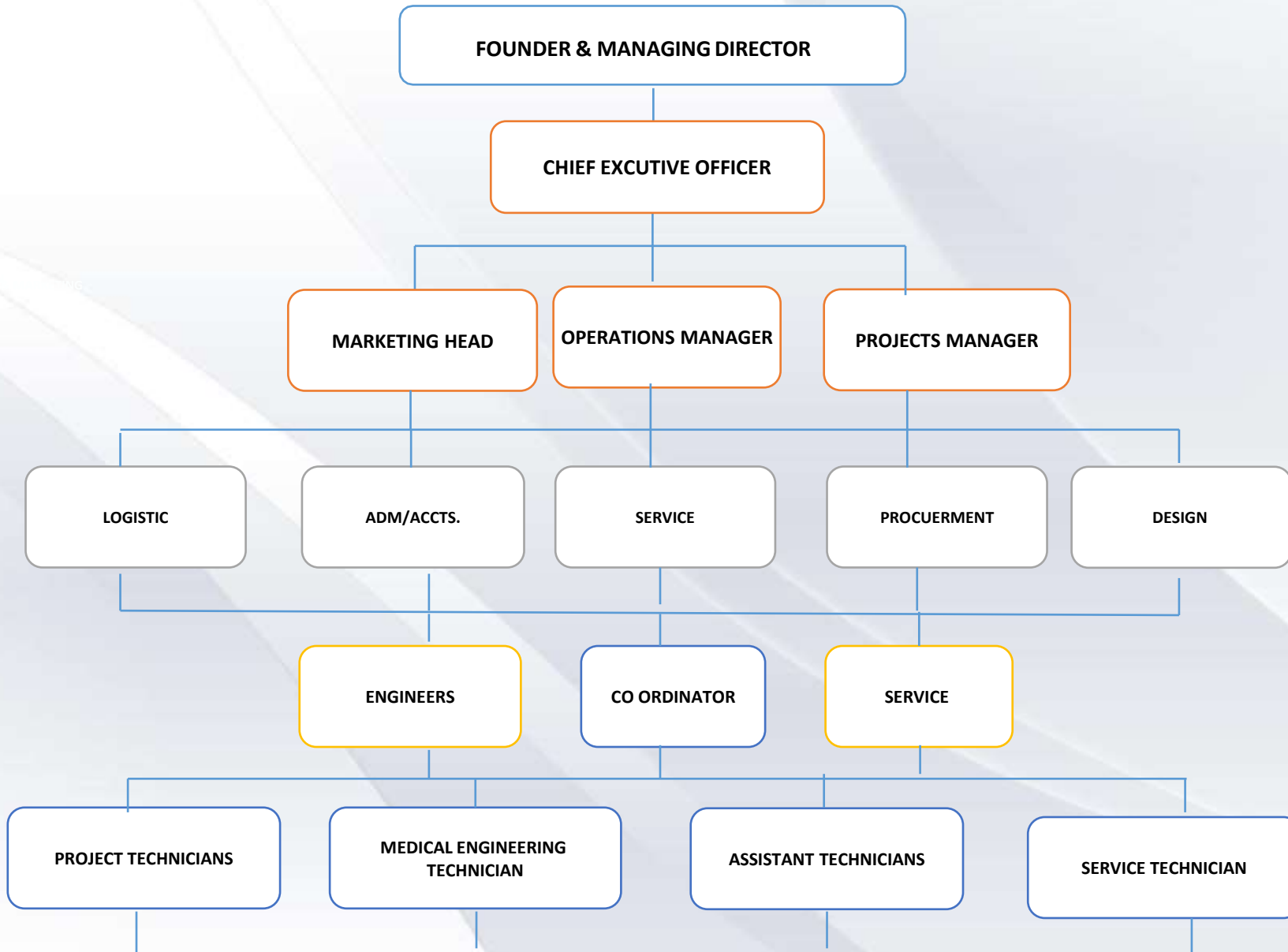



Reference Projects

Ongoing Projects - 2024

- ASAN Gastroenterology Specialty Hospital – DHCC (200 Bed)
- Al Sharq Hospital, Dibba, Fujairah (200 Bed)
- Cosmomed Hospital, Fujairah (50 Bed)
- Cosmomed IVF Center, Fujairah (50 Bed)
- American IVF Center, Sharjah (50 bed)
- Orchid IVF Center, Dubai (50 Bed)
- IVF International Clinic, Barsha, Dubai (50 Bed)
- Fujairah Research Center, Fujairah (50 Bed)
- Life Line Hospital (LLH) – Mango Mall, Dubai (50 Bed)
- Prime Hospital Medical Centers (Motor City, Al Warqa, Reef Mall, Dubai)
- Govt. Peripheral Hospital Periyar Nagar, Chennai, India (430 Bed)
- Fakhee University Clinic, Dubai Mall, Dubai (50 Bed)
- NMC Royal Hospital, DIP, Dubai (200 Bed)
- Al Nokba Rehabilitation Centre, Abu Dhabi (50 Bed)
- Latifa Hospital Ward Extension, Dubai (50 Bed)
- Al Zahra Hospital OPD, Barsha, Dubai (50 Bed)
- Ethihad Airways Medical Centre, Abu Dhabi (50 Bed)
- Burjeel Medeor Extension Project, Abu Dhabi (50 Bed)
- PHCCs under Dubai Academic Health Corporation
- International Modern Hospital Renovation, Dubai (100 Bed)
- O.P Block - Kilpauk Medical College Hospital, Chennai, India (100 Bed)
- Cemonc Block - Kilpauk Medical College Hospital, Chennai, India(120 Bed)

Reference Projects

Completed Project

- DHA - Rashid Hospital. DHA - Dubai Hospital.
- DHA Latifa Hospital. DHA PHCC total 20 no's
- Sheikh Khalifa Hospital –GH -Ajman
- Sheikh Khalifa Hospital-Ajman.
- Sheikh Khalifa Hospital Ajman. – OPD.
- Sheikh Khalifa Hospital Umm Al Quwain.
- Sheikh Khalifa Hospital Masfoot.
- NMC Hospital, Al Nada, Dubai.
- NMC-Hospital-Abudhabi (Building No.3 & Tower Buld.S1).
- NMC Royal Hospital Khalifa City-A.
- NMC Royal Hospital. DIP. Dubai
- NMC Specialty Hospital (Blue) Dubai.
- Life Line Hospital, Jebel Ali, Dubai
- Health Plus IVF Centre, Abu Dhabi
- Bourn Hall Fertility IVF Centre, Dubai
- Al Barsha Health Centre Barsha, Dubai
- London Surgery Centre, Dubai
- Cocoon Day Surgical Centre, Dubai
- Medicentre Day Surgical DSO, Dubai
- Boston Medicals, DLCC, Dubai
- NMC Hospital - Abu Dhabi
- NMC Hospital - Al Ain
- NMC Hospital – Dubai
- Arzana Medical Complex, Abu Dhabi
- Maliha Hospital, Sharjah
- Emirates Hospital, Dubai
- Euro Arabian Hospital, Sharjah
- Danat Emerat Hospital, Abu Dhabi
- Capital Health, Abu Dhabi
- Sapphire Day Surgery Center, Dubai
- Ministry of Presidential Affairs, Ajman
- Al Soha Al Shifa Medical Center, Sharjah
- Imperial College of London, Abu Dhabi
- Mediclinic, Al Ain
- Dr.Haifa Eye Hospital, Bahrain
- Al Ain Fertility Center, Al Ain
- Seha Emirats Hospital, Abu Dhabi
- Tadawi Health Centre, Dubai
- Moofiled Eye Centre, Dubai
- Kuwaity Hospital, Dubai
- Aster Hospital, Dubai
- Med Care Hospital, Dubai
- Himalaya Medicine Lab, Dubai
- Al Zahra Hospital, Dubai



Reference Projects

Completed Project

- Bareen Hospital, Abu Dhabi
- Dubai Health Authority, Dubai
- National Hospital, Abu Dhabi
- Al Raha Hospital, Abu Dhabi
- Al Noor Hospital, Abu Dhabi
- Park Medical Center, Abu Dhabi
- Advanced Center for Day care-Abu Dhabi
- Yas Healthcare, Abu Dhabi
- Ebbsar Surgery Center, Dubai (Spanish)
- Highness Day care Surgery, DHCC, Dubai
- Dar al oyoun eye hospital, Sharjah
- Magrabi Medical Center, Abu Dhabi
- Prime Medical Center, Dubai
- Dubai London Clinic, Jumeirah, Dubai
- King's college Hospital, Abudhabi
- Kuwaiti Hospital, Sharjah
- King Hamad Hospital, Bahrain
- KIMS Hospital, Muscat
- Al Wakra Dialysis Hospital- Qatar
- Cardiac Hospital, Doha, Qatar
- Medical City, Doha – Qatar
- Sidra Hospital, Doha – Qatar
- Al Ahli Hospital, Qatar
- ABM Military College, Qatar
- Jahra Medical Centre, Kuwait
- Al Moosa Hospital, KSA
- Al Moosa Hospital, KSA
- Orthopedic & Spin hospital, Bangladesh
- American Mission Hospital- Bahrain
- Salmaniya Hospital Renovation- Bahrain
- Teaching Hospital, Bahrain
- Apollo Hospital, Mauritius
- Jeetoo Hospital, Mauritius



Products & Services

- Medical/Laboratory Gas System
- Nurse Call System
- Pneumatic Tubing Systems
- Architectural Systems
- Modular Operating Theater
- CSSD (Sterilization) equipment
- Medical Equipment
- Medical furniture
- Clean Room validation
- Pressure Monitoring System
- Diffuser with HEPA
- Pressure Control Systems
- Centralized Clock System
- UPS & IPS Systems
- Hermetically Sealed Doors
- Radiology Protection Systems
- Laminar Flow ceiling
- Maintenance of Medical engineering
- Health Care Maintenance
- Specialized HVAC System
- Healthcare Energy Saving
- Gas Detection System

Medical & Lab Gas System



Unicorn Medicals is a leading supplier of medical gas equipment, including medical air plants, medical vacuum plants, WAGD plants, manifolds, Liquid Oxygen Tanks, Oxygen Generators, Manifold systems and pipeline components to NFPA 99 standards and HTM 02-01 / ISO, EN standards. Medical gas service and support is central to everything we offer our customers, and we maintain the largest service force dedicated exclusively to medical gas.



Dental & Lab Gas System

Ultra-dry, oil free is even important. Compressor that isn't built specifically for dental / Lab use cannot deliver dental / lab quality air and ultimately puts both your patients and instruments at risk. That alone should be reason enough for you to choose our Dental systems. we are offering Dental air and Vacuum systems custom designed and built specially for dental / lab application. we supply, installation & Commissioning the Dental & Lab Equipments as per Hospital requirements and according to the standards.

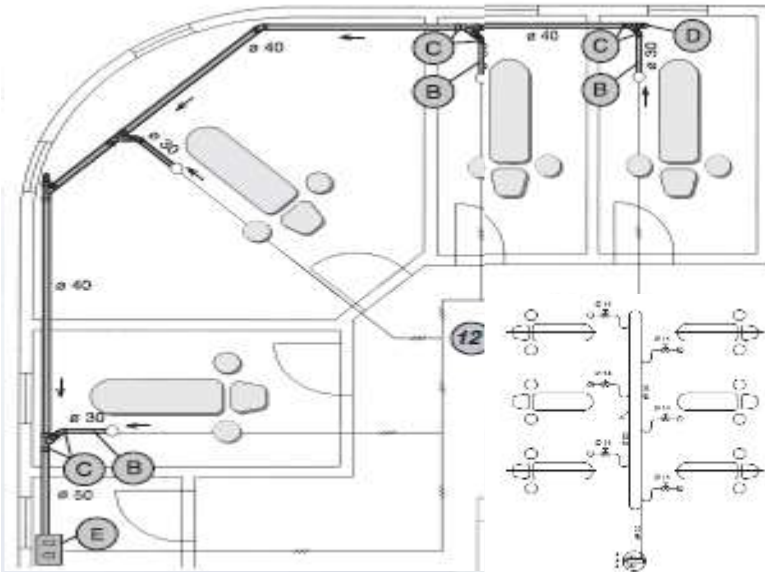

Centralized Clock System

Sapling Inc. has been a pioneer in synchronized timekeeping systems for more than two decades. As an organization, we strive towards innovation and reliability. Sapling clocks can be found in schools, hospitals and industries throughout the country and all over the world. We feature a complete line of analog and digital clock products for systems such as Wired, IP, Talk Back and our most popular innovation, the synchronized Wireless clock system which, is based upon our patented frequency-hopping technology that has transformed the industry

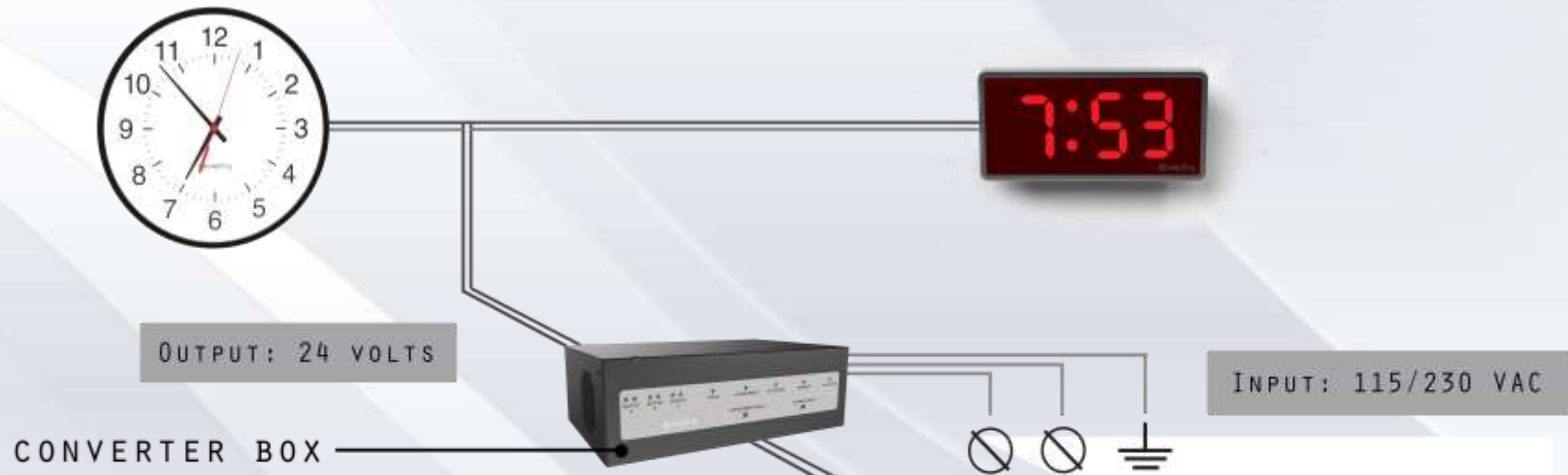

Pneumatic System

Pneumatic tube system is an integral part of every modern hospital worldwide, developing from what was once the simple transport of blood samples, blood bags or drugs from point A to point B, to state of the art computer controlled systems. These computer controlled pneumatic tube systems provide safe transfer points to both nursing/medical staff and to fully automated laboratory lines and pharmacies, ensuring each processing step is monitored and logged in real time.



Nurse Call System



Nurse call is much more than just patient communication. The innovative system platform creates an open system structure, which integrates smoothly into current and future technologies. In this way, not only a much more powerful infrastructure can be created in hospitals, but also a new level of comfort, safety and efficiency. New ways are taken and open up completely new possibilities for the highest quality of care.



Modular Operating System



We offer a prefabricated modular wall system especially for the interior furnishing of the operating-wing. The walls are designed to come up to both medical and constructional requirements. Prefabricated wall system offers the possibility to include in the planning stages complicated installations with different needs, such as air-conditioning, heating, sanitation, high- and low-voltage supply, electro-medical apparatus, medical gases, as well as fulfilling of needs for X-ray shielding, noise- and fire protection. prefabricated wall system is a prefabricated modular operating room system.



Modular Operating System



Modular Operating System



Clean Room System



Our system is fully flush, from top to bottom, and gives you total freedom to install doors, windows or power outlets, cabling, pipes, wherever you wish. It allows for flush built-in ventilation ducts, curved edges etc... You build the wall as you go, including flush floor integration. You can insert doors and windows as required in a pre-fitted flush profile, and can continue building. Fully flush is the key concept here. PLUS is an ideal solution for areas involving injectables, biotechnology or microelectronics.



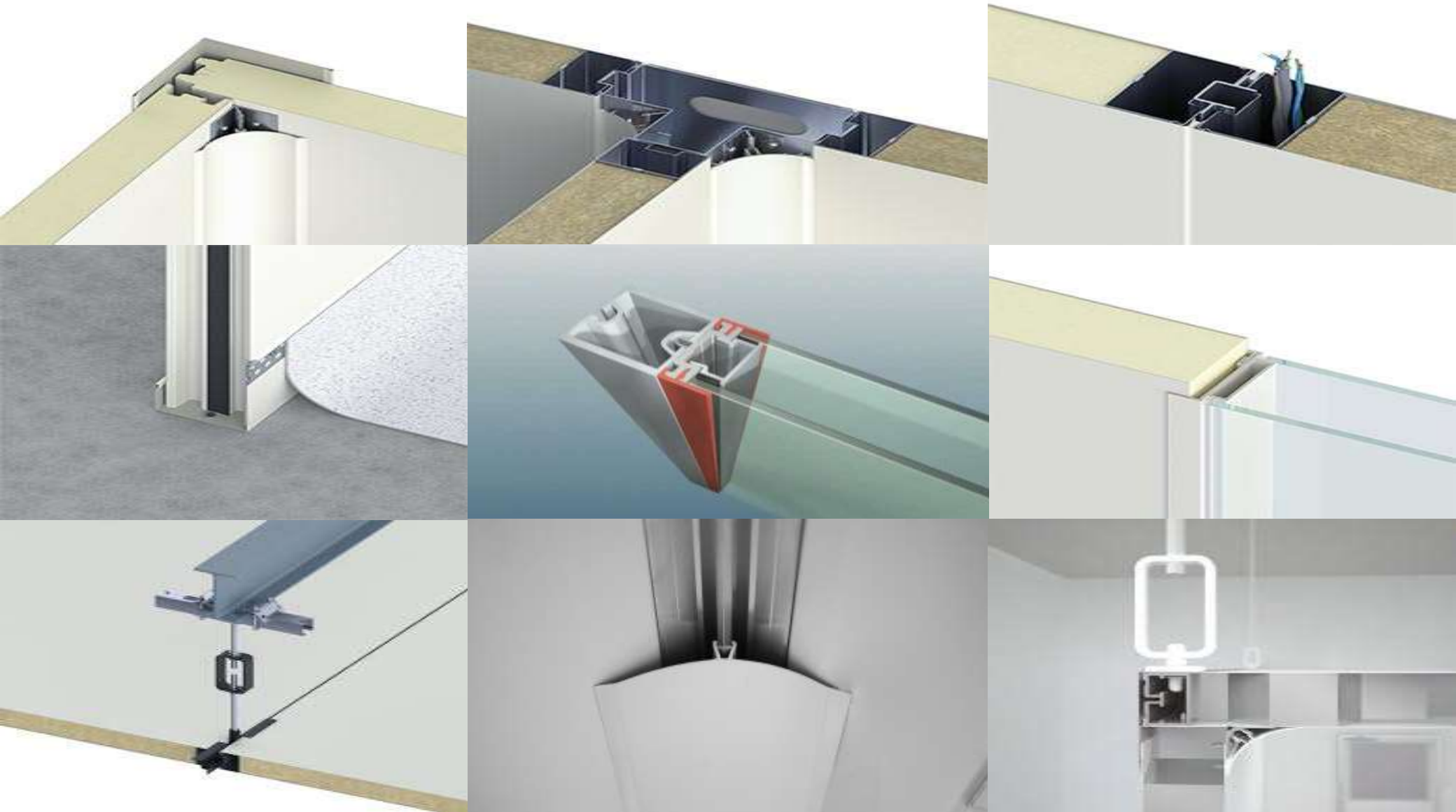

Clean Room System

Our antimicrobial wall cladding ranges kill bacteria and prevent the spread of germs or contaminants in medical facilities, laboratories, cleanrooms, foodsafe environments, commercial kitchens, manufacturing plants, nurseries, schools and offices. Hygienic PVC wall panel range is made from premium- grade material and is cost-effective and versatile. Our PVC wall covering panels are non-toxic and have a proven track record in environments where strict hygiene standards must be maintained. The wall Clad team are experienced in all aspects of wall cladding installation, quantity calculations, hygienic performance and the compatibility of each system for the intended location.

LONG YEAR GUARANTEE

Our systems are premium, long-lasting wall cladding solution and have a Long Year Guarantee. The smooth Clad surface and the textured Guard surface are highly resistant to chemicals. Germs cannot gain a foothold. This makes cleaning, quick and easy and any traces of bacteria and virus cannot re-form on the panel's surface. The antimicrobial properties are added to the Clad and Guard sheets during manufacturing. Tiny particles of silver ions deliver an authentic sterile performance. The ingredients contain no toxins and actively prevent the growth of bacteria, mold and viruses – including MRSA and food contaminants. Our Wall Protection is 20 times more scratch-resistant than standard PVC panels and wall Clad are Antimicrobial and Hygienic Wall Panels are suitable for a huge range of wall cladding jobs in hygiene-critical and foodsafe areas.



Laminar Flow System



The ceilings are available in square, rectangular, octagonal or circular shapes In order to suit any room layout and answer specific requirements to create a clean zone around the patient, medical staff and medical devices. Our laminar flow ceilings are mainly used with our Clinic Air Handling Unit but can be also adapted to any type of products from a different brand This system is dedicated to operating theatres in order to meet ISO 5 standard (complying with EN ISO 14644-1) as well as to pharmaceutical industry. It helps fight cross contamination and hospital borne infections.



Isolation Room Negative or Operating room pressure control

This Isolation Unit is made for installation in suspended or false ceilings, and walls. Can be connected to an existing ventilation system or new tube system. Recommended for installations where the point of extraction and supply are further away from each other. Depending on the installation, positive (for immune-compromised) or negative (for infectious patients) pressure is generated inside the room (easily up to 20 Pascal). Filters used in this Isolation Unit are of HEPA14 or ULPA15 quality, leak tested and airtight secured. ISO520 can be used with Remote Control RC100 or RC200.



HEPA Filter Diffuser



Air back-pressure flap



Fire protection flap



Remote controller RC 100
wall mounted



Remote controller RC 200
wall mounted

Medical Engineering in Operating Room



MEDICAL provides innovative solutions and products for operating theatres, hybrid operating rooms, ICU/NICU units, surgical preparation rooms and other hospital areas. We install ORs and supply medical equipment for hospitals all over the world since almost 15 years: modular walls and ceilings, operating tables, surgical scrub sinks, OR doors, medical trolleys, patient transfer systems and furniture. The Unicorn solution for complete integration of devices and medical image management enhances workflow efficiency and improves patient care in the OR.





Bed Head Units

Leading Medical Supply Unit and provider of Bedhead & Medical Trunking for the healthcare sector. Designers and suppliers of extruded aluminum cable management trunking systems for use in the worldwide commercial and healthcare markets. As the leading Medical Supply Unit supplier for the healthcare sector we are broadly credited within the GCC as being the innovators in bedhead services trunking system solution where our products have gained notable recognition around the world via our international supply network.



Ceiling Suspended System



Hermetically Sealed Doors

OT is the most complex area hence most expensive function of a Hospital. Considering its nature of high risk for Patient Safety, we need utmost hygiene level with Purest Air. We install Hermetic Sealed Sliding and Swings doors are ideal for application in critical areas like OT Rooms, ICU, X-Ray Rooms and other places like passage areas.



Radiology Protection & Lead Cladding



We are also specialized in supply, installation and commissioning of lead Shielding for use in radiology environments. Our mission is to offer the very highest levels of radiation protection to our clients across world. We provides Sheet Lead with a consistent and high density manufactured from pure lead conforming to ASTM B-29, B-749 and Federal QQ-L-201F, QQ-L-171E. We use only the purest lead available. Our sheet lead is 99.94% pure lead. Absolutely no refining is performed in the manufacturing of our sheet lead. We interested in providing its customers with the highest quality sheet lead available in the market place today.

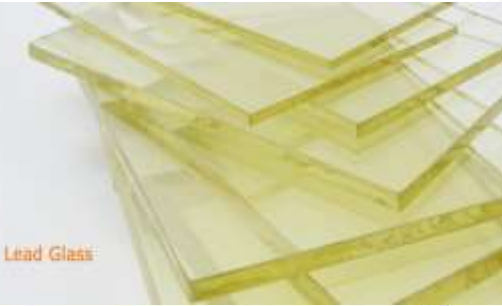

Lead Glass



CAUTION
X-RAY
IN USE

CONTROLLED AREA

RADIATION
RADIATION PROTECTION REGULATIONS REQUIRE THAT THIS DOOR BE KEPT CLOSED DURING X-RAY EXPOSURE

X-Rays
Do not enter when red light is on

Radiation
Controlled area

Sterilization and Infection Control Solutions

Unicorn Provide complete solutions for CSSD that include Department consultation, Design, equipment's supply, Quality assured consumables, sterilization packaging material, waste management solutions and the most advanced instrument traceability solution. We deliver the top of the range of CSSD equipment, lab sterilizations products and mortuary excellent after sales service, Unicorn provide easy to use, and high-quality products allowing hospitals in limiting the infection ration which in return protect and enhance patients' safety



HealthCare Beds & Furnitures



Unicorn Provide complete solutions for Hospital range of medical furniture include hospital beds for various purposes, complete furniture solutions for examination rooms, Electric Hospital Beds, medical trolleys, as well as special geriatric furniture, support, and accessories. We distribute medical furniture brands with service assistance



Pass Through Box – Medical Fridge & Warming Cabinet

We Provide complete solutions for Hospital range of pass boxes, warming cabinet and Medical fridges and related complete solution specifically manufactured for clean room systems and solutions with technical support and service assistance



24X7 - ON CALL SERVICES

WE have been maintaining Hospital Facilities since 2007 over period of Fifteen years, We have gained wide range of experience in the different fields of Medical gas systems, Nurse call systems, Pneumatic systems, Medical Engineering and Facility management. Furthermore, our effort to always stive for service excellence, we have developed our own unique slandered operating procedure which has proven effective for so many years in consistently meeting our clients needs, We have well trained and well motivated employees so that we can provide our clients with the highest quality of service that they deserve



HVAC System & Energy Saving

The strategy of adjusting and optimizing energy, using systems and procedures so as to reduce energy requirements per unit of output

- Proc ure energy at lowest possible price
- Manage energy use at highest energy efficiency
- Reusing and recycling energy
- Select low investment technology to meet present requirement and environmental condition
- Make use of wastes generated within the plant as sources of energy and reducing the component of purchased fuels and bills

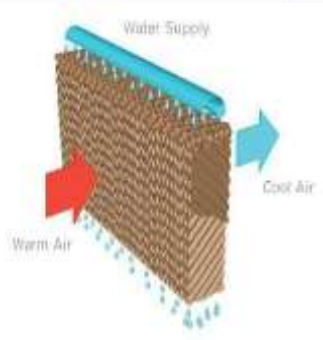
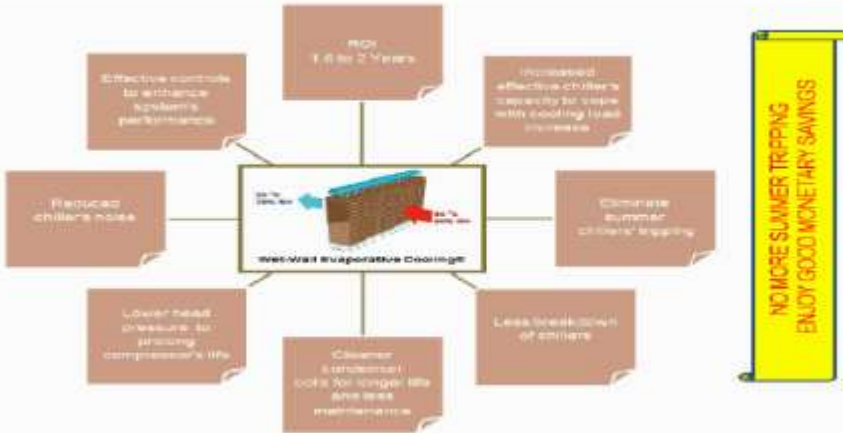

Interior Design and Fitout



Unicorn create medical center designs & fit out that facilitate the provision of all health services required by the community through the provision of logical and workable space provisions while also maintaining sensitivity to the local environment. Interior design Dubai create designs that provide continued functionality in event of disasters or emergency. Our designs create adequate safety and security for patients and healthcare providers.



Thanking you

- *A company that cares about quality products and Clients comfort*
- *Many More than just a Supplier of Industrial & Healthcare Engineering products.*
- *A partner you can rely on and enjoy “doing” business with.*
- *Provides system design, Supply, Installation, Commissioning, after service and product support.*



An MOH Licensed Company

UNICORN MEDICALS LLC

OFFICE/WH No: 15, ABDULLA ALI BIN HAIDER BUILDING,
UMM AL RAMOOL
DUBAI – UAE, Po. Box. 231673

Tel: 00971 4 2500178, Mob: 00971 50 4759990, Email: info@unicornmed.com; s.john@unicornmed.com

